

Thermax® **CP3**

PROFESSIONAL HOT WATER EXTRACTION CLEANING SYSTEM

OWNER/ OPERATOR MANUAL



 **Thermax**

Products for a Healthier Indoor Environment

thermaxaf.com

1-888-764-3700

TABLE OF CONTENTS

Message from the Corporate Office	2
Identifying Features	3
Inspection Upon Delivery.....	4
Important Safety Information	4
Set-Up Procedure.....	5
Extraction Cleaning Procedure.....	5
System Clean-Up	6
General System Maintenance	6
Optional Package and Accessories	7, 8
Rental Center Benefits	9
Cleaning Solutions.....	10
Air Purifiers and Solutions	10
CP3 Specifications	11
CP3 Wiring Diagram.....	11
Troubleshooting	12
CP3 Base Unit Schematic	13
CP3 Base Unit Parts List.....	14
Floor Wand Schematic	15
Floor Wand Parts List	16
Upholstery Wand Schematic	17
Upholstery Wand Parts List.....	18
Power Brush Schematic	19
Power Brush Parts List	20
Additional Commercial Units	21
Thermax Warranty	22

MESSAGE FROM THE CORPORATE OFFICE



Todd Walker, CFO,
Jason Davis, CEO,
and Mark Rodie, COO

Congratulations on the purchase of your new Thermax CP3 Professional Hot Water Extraction Cleaning System! In 1971, Thermax founder Carl Parise developed the world's first UL approved carpet steam cleaner for the U.S. market, and has since produced over 500,000 units sold worldwide. We have adopted our own brand name, Thermax, which is rapidly becoming a household name, synonymous with the industry.

In an industry full of competition and choices, we at Thermax are grateful for your wise choice of the Thermax CP3, and we look forward to a lasting relationship as we service all your business needs.

Your new CP3 is a high performance workhorse. When maintained and operated in accordance with this owner/operator manual, it will give you years of quality service.

For over three decades, Thermax has produced fine quality, portable, hot water extraction cleaning systems for the home, hotel/motel, auto detail, janitorial, as well as other commercial markets. The Thermax CP3 portable rental system pioneered the do-it-yourself rental steam cleaner* market, introducing America to a new way to clean carpets.

Our company and staff subscribe to the philosophy that our relationship with you the customer doesn't end with the sale, it only begins. If there is any area in which we can be of service, please call the Thermax Customer Support Center at 1-888-764-3700.

Thank you for joining the ever-growing family of Thermax owners. Here's to many years of use and, most importantly, here's to a healthier indoor environment.

**Steam cleaning is the generic technology used to describe the hot water extraction process of cleaning carpet.*

IDENTIFYING FEATURES



- 1) Clean Solution Tank
- 2) Stationary Lid with Solution Tank Fill Hole
- 3) Recovery Waste Tank
- 4) Recovery Tank Dome and Vacuum Seal
- 5) Power Cord
- 6) Brass Female Quick Connect Coupling
for the Solution Hose
- 7) Auxiliary Female Outlet for the
Optional Power Brush
- 8) Vacuum Inlet/Vacuum Hose Connector
- 9) Pump/Heater Switch
- 10) Vacuum Switch
- 11) Easy Pull Handle

INSPECTION UPON DELIVERY

Carefully unpack and inspect the Thermax CP3 and be sure all components ordered are included. Orders might be packed in more than one box.

NOTE: Contact the carrier immediately regarding any damage incurred during shipping as it is your responsibility to file a damage claim with the carrier.

IMPORTANT SAFETY INFORMATION

- 1) To prevent the possibility of electrical shock, always unplug the system from the main power source before physically inspecting or attempting to repair the system.
- 2) Inspect system daily, especially when used by someone else. Inspect for damaged components such as loose wires, frayed cords, missing ground pin, etc.
- 3) Only operate system when it is properly grounded. Improper grounding could result in serious or fatal shock!
- 4) When operating the system around water, during flood restoration, etc., always outfit yourself properly with rubber-soled shoes or rubber boots and do not set system in standing water.
- 5) To keep from voiding your warranty, use only those cleaning solutions manufactured by Thermax and never use solvent based products.
- 6) After use, always thoroughly rinse and clean both recovery and solution tanks. If using recovery tank to store hoses, or other miscellaneous items, always clean items before storing them in tanks.
- 7) Do not operate solution pump dry.
- 8) Do not store where temperatures drop below freezing, as this may damage the pump.
- 9) Always use defoamer in recovery tank to prevent the motor from being damaged from overfoaming.
- 10) Extension cord should have a minimum rating of 12/3 (#12 cord). Extension cord should not exceed 50 feet.
- 11) Never open up the system when there is water in either the solution or recovery tank, remove the solution and waste water first.

SET-UP PROCEDURE

- 1) Pre-mix cleaning solution as required for specific application in a five gallon (19 liter) pail. Pour pre-mixed solution through solution fill hole of system (page 3, #2).

NOTE: This system has a built-in solution heat maintenance feature, start with hot water if possible. Hot water is hygienic and maximizes cleaning potential.

- 2) Add appropriate amount of defoamer to the recovery tank (page 3, #3).
- 3) Connect end of the vacuum hose to the vacuum inlet connector (page 3, #8).
- 4) Connect male end of the solution hose to female quick-connect coupling (page 3, #6), and female end of solution hose to the male end of the cleaning wand.
- 5) With solution tank full and vacuum and solution hoses properly connected, plug main power cord (page 3, #5) into properly grounded outlet.

NOTE: Plug the cord into an outlet that will be out of the way of the cleaning path, ideally a 20 amp circuit when available.

- 6) Your system is now ready for operation.
- 7) Once pre-spray, furniture removal and other carpet preparation is complete, proceed to clean carpet and/or upholstery.

NOTE: Vacuum and pump switches can now be activated to "ON" position.

EXTRACTION CLEANING PROCEDURE

- 1) With solution tank full and all hoses appropriately attached, activate pump switch to the "ON" position, then activate the vacuum switch to the "ON" position.
- 2) Start in area of the room opposite from where you want to end.
- 3) Place wand about 4 feet in front of you.
- 4) Activate the solution spray trigger of wand.
- 5) Laying down an even spray of solution, pull the wand back towards you slowly.
- 6) Release the solution spray trigger and move the wand slowly forward over the same area just cleaned to recover additional solution left behind. Repeat this process several times depending on the degree of carpet soiling then move over the width of the wand, overlapping slightly to prevent streaking. For best results, work in approximately 4 foot wide sections and always be sure to remove as much solution from the carpet as possible as this will minimize drying time.
- 7) When solution tank is empty and needs refilling, shut system down and repeat step 1 of "Set Up Procedure".
- 8) Remove, empty and replace recovery holding tank. (page 3, #3).

NOTE: Always empty and replace recovery tank at the same time you refill the solution tank.

- 9) Add more defoamer into the recovery holding tank (step 2 of "Set Up Procedure").

NOTE: With solution tank full and recovery tank empty, the system is now ready to continue cleaning. Continue the process until cleaning is complete.

SYSTEM CLEAN-UP

When the carpet cleaning process is complete, it's time to clean the system. De-activate all switches to "OFF" position.

- 1) Empty and rinse recovery tank.
 - 2) Empty solution tank.
 - a. To empty solution tank of unused solution, turn vacuum switch to "ON" position.
 - b. With vacuum hose still connected to the inlet and vacuum running, drop the end of the vacuum hose (opposite the end plugged into the vacuum inlet) down through the solution tank fill hole (page 3, #2) and SLOWLY remove the unused solution from the solution tank until empty. The system will transfer the solution to the recovery waste tank for disposal. In the process, the solution cleans out the inside of the vacuum hose.
- NOTE:** Take caution to remove the solution SLOWLY! Make sure to rinse solution tank with the plain hot water to minimize chemical build-up. After rinsing solution tank, transfer rinse water in the same manner mentioned above.
- c. Deactivate and unplug the system
 - d. Empty the recovery tank and clean.
 - e. Remove vacuum and solution hose from system. Wipe down all exterior areas of the system.
- 3) Your CP3 system is now ready for storage until the next job!

GENERAL SYSTEM MAINTENANCE

DAILY (At the conclusion of each work day)

- 1) Empty, rinse and clean solution and recovery tanks with plain hot water thoroughly cleaning dirt and obstructions from inside the tanks.
- 2) Clean vacuum and solution hoses thoroughly.
- 3) Run plain hot water through solution tank and pump to prevent any chemical build-up.
- 4) Wipe down all exterior surfaces with an all-purpose type cleaner, then apply a light coat of vinyl protectant to all exterior surfaces.
- 5) Lubricate couplings, hinges and wheels with silicone-type spray.
- 6) Inspect the solution tank filter and recovery tank dome filter for hair and debris. The filter should always be kept clean and unobstructed.
- 7) Inspect electrical cord for damage or fraying and repair as necessary.
- 8) Store unit away from direct sunlight and freezing temperature.

MONTHLY

- 1) Inspect internally for:
 - a. Loose nuts and/or screws
 - b. Leaking hoses
 - c. Loose wiring
 - d. Anything that doesn't appear correct
- 2) Flush the system with 2 cups white vinegar per gallon of hot water solution. Follow by circulating plain hot water through the system via the solution tank. This helps reduce and neutralize any alkalai and chemical build-up.

NOTE: To prevent shock hazard, remember to unplug main power source before inspection or repair of the system.

ANNUALLY

We recommend that your system be inspected once a year by an authorized Thermax service technician. For the location of your nearest Service Center, call 1-888-764-3700 or go to thermaxaf.com.

OPTIONAL PACKAGES & ACCESSORIES

The following optional packages and accessories do not come standard with your CP3. Contact your local distributor or the Corporate Office to receive details on how to purchase these items.



DELUXE RENTAL PACKAGE
PART # 32-700-HAH
Includes: Clear View Floor
Wand, Upholstery Wand,
& 10' Hide-A-Hose



CLEAR VIEW HAND WAND
PART # 35-255-004



10' HIDE-A-HOSE
PART # 10-HAH-3

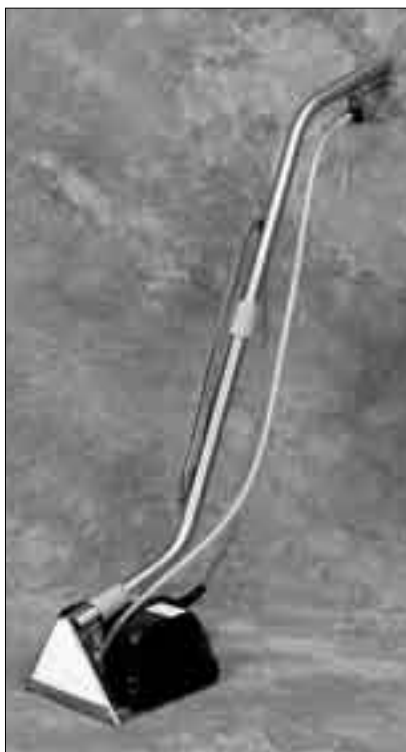

PB309 – OSCILLATING
POWER BRUSH
PART # 80-012-121

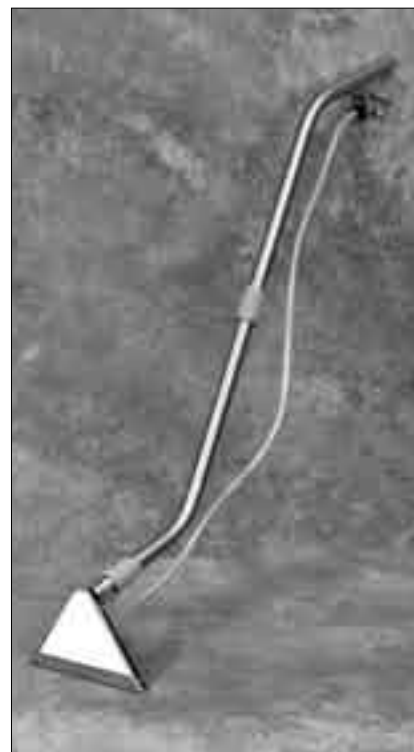

CLEAR VIEW FLOOR WAND
PART # 29-760-325-1

OPTIONAL ACCESSORIES CONTINUED



15' HIDE-A-HOSE W/
BUILT-ON SS DETAILS
PART # U1570-15-CP5

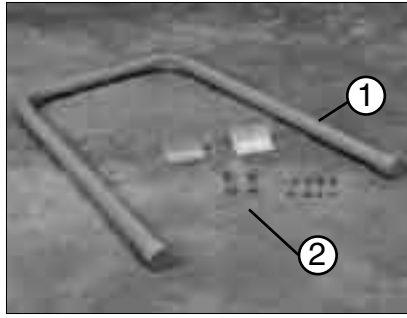

EASY-PULL HANDLE W/HARDWARE
PVC HANDLE W/HARDWARE, PART # CP3-HAN-ASSY
1) PVC HANDLE, PART # CP3-HAN
2) HARDWARE, PART # CP3-HAN-HDW



SINGLE UNIT HEADER SIGN
PART # F-HS-1UMR



DOUBLE UNIT HEADER SIGN
PART # F-HS-2UMR



SINGLE UNIT RENTAL
RACK, METAL
PART # 32-502-01



DOUBLE UNIT RENTAL
RACK, METAL
PART # 32-502-02



OUTSIDE FRAME W/INSERT SIGN
1) FRAME: PART # WORS-F
2) SIGN: PART # WORS-I

Profits! Profits! Profits!

Thermax Rental Centers

Also Offer The Breeze®
Water Based Air Purifier



Thermax Rental Center
Commercially Clean Your Carpets & Upholstery

\$19.99 \$29.99

Double
Unit



Optional Power Brush

Optional Upholstery Tool



Call for information on how to receive an exclusive territory for setting up Thermax Rental Centers at retail locations in your area.

- Hardware Stores
- Grocery Stores
- Drug Stores
- Dry Cleaners
- Any High-traffic Retail Store

IMPORTANT REMINDERS:

Thermax's upcoming national advertising and marketing campaigns will create a tremendous amount of new rental customers in your area.

Being recognized by the corporate website as an Authorized Thermax Rental Center will allow you the opportunity to receive referred national retail accounts in your distributing area.



Outdoor
Signage
available!



Single Unit

Offer your customers

The World's Best Carpet Steam Cleaner

- Owning your own rental center will finally allow you to make 100% of the profits
- Offer a unique service, separating yourself from your competition
- Draws customers into your store twice in 24 hours to purchase other items
- Self-contained rental center can cater up to 20 machines per location
- Compact, requires little space (2x2' or 2x4')
- Attractive display that draws attention and increases business.
- Earn over \$175 per sq. ft. per month
- Pays for itself in as little as 6 months
- High volume solution holding racks
- Includes built-in heater that heats to 175°
- Stainless steel tanks & wands for quality and durability
- Extracts over 90% of water
- Drying time is less than 1 hour
- Low maintenance
- Preferred 4 to 1 over leading competitors

 **Thermax**®

Products for a Healthier Indoor Environment

visit www.thermaxaf.com or call 1-888-764-3700

STEAM CLEANING SOLUTIONS

Nearly thirty-five years of extensive field use and refinement have proven our safe and effective cleaning solution formulas. Thermax has a product for just about every carpet cleaning application. Formulated specifically to be used in conjunction with Thermax AF2 carpet cleaning systems the products and their application are further defined below.



LIQUID CARPET & UPHOLSTERY CLEANER (6060-I): (16 or 32oz.) Designed to lift oils, stains, and deeply embedded soils from carpet & upholstery for easy extraction. Professionally formulated to dispense a perfect blend of gentle yet effective cleansing agents for cleaning carpets. Cleans and brightens leaving carpets soft to the touch with no “soapy” residue.



CITRUS DEODORIZER (5080-I): (32oz.) While steam cleaning, it neutralizes and removes offensive odors from carpet & upholstery at their source, especially pet urine, smoke and other organic matters. Leaves a fresh, pleasant scent.



BIO-ENZYME STAIN & PET ODOR ELIMINATOR (5150-I): (32oz.) Liquifies and digests organic waste, through beneficial bacterial enzyme action. Eliminates old and new odors at their source. Product is safe to use around pets, humans, and environment. No harsh chemicals. Cleanses and deodorizes.



PRE-SPOTTER (6030-I): (32oz.) Great for pre-treating heavily stained carpets & upholstery before steam cleaning. Loosens stubborn stains, oils, and dirt from the fibers for easy removal with any Thermax system. The use of Pre-Spotter is an important step in obtaining the best cleaning results.



DEFOAMER (6070-I): Defoamer is used in the solution recovery tank to control potentially damaging foam build-up within the tank. Every carpet being cleaned contains foreign matter within its fibers. Often times, this foreign matter has a tendency to excessively foam when extracted into the recovery tank of the cleaning system. Using Defoamer while cleaning minimizes the potential for the foam to overflow into the vacuum motor.

AIR PURIFIERS AND SOLUTIONS



THE BREEZE® AND GENTLE BREEZE® WATER-BASED AIR PURIFIER AND FRESHENERS:

These miniature water-based air fresheners work off the same concept as the AF2. The Breeze® and Gentle Breeze® use the deodorizers & aromatizers listed above. The Breeze® is designed to freshen the air in your home (up to 800 sq. feet), while the Gentle Breeze® comes equipped with a power cord suited for your home or vehicle (up to 200 sq. feet).



AQUA BLUE DEODORIZER & SANITIZER: (19-310-00-I) 8 oz. This is a concentrated blend of proprietary elements that therapeutically clean and freshen your indoor environment, neutralizing any harmful germs and bacteria when used as directed. Just add the required amount into the water of the recovery/filtration tank before and during vacuuming to achieve the desired result. Your home will permeate with a fresh, clean, healthy aroma!



AROMATIZERS:

Visit thermaxaf.com or call 1-888-764-3700 to order the fragrance of your choice. Each bottle is sold separately, and contains 1.6 oz oil-based solution used for leaving an aromatizing scent behind while purifying the air. Mulberry, Eucalyptus/Menthol, Cinnamon & Spice, Vanilla, Lemon, Lavendar, Fresh Linen, Citronella, Italian Cream Cake, & China Rose. Lavendar helps reduce the pain of headaches and soothes the mind.

THERMAX CP3 SPECIFICATIONS

DIMENSIONS:

- Length 28"
- Width 17"
- Height 26"
- Weight 39 lbs.

RECOVERY TANK:

- Hygienic Stainless Steel
- 3 U.S. Gallons

SOLUTION TANK:

- Hygienic Stainless Steel
- 3 U.S. Gallons
- 300 Watt Heating Element

ELECTRICAL:

- 115 Volt AC
- 11.5 AMP
- 50/60 HZ
- CE

VACUUM MOTOR:

- 2-Stage By-Pass
- 112" Water Lift

PUMP:

- 60 P.S.I.

THERMAX CP3 WIRING DIAGRAM

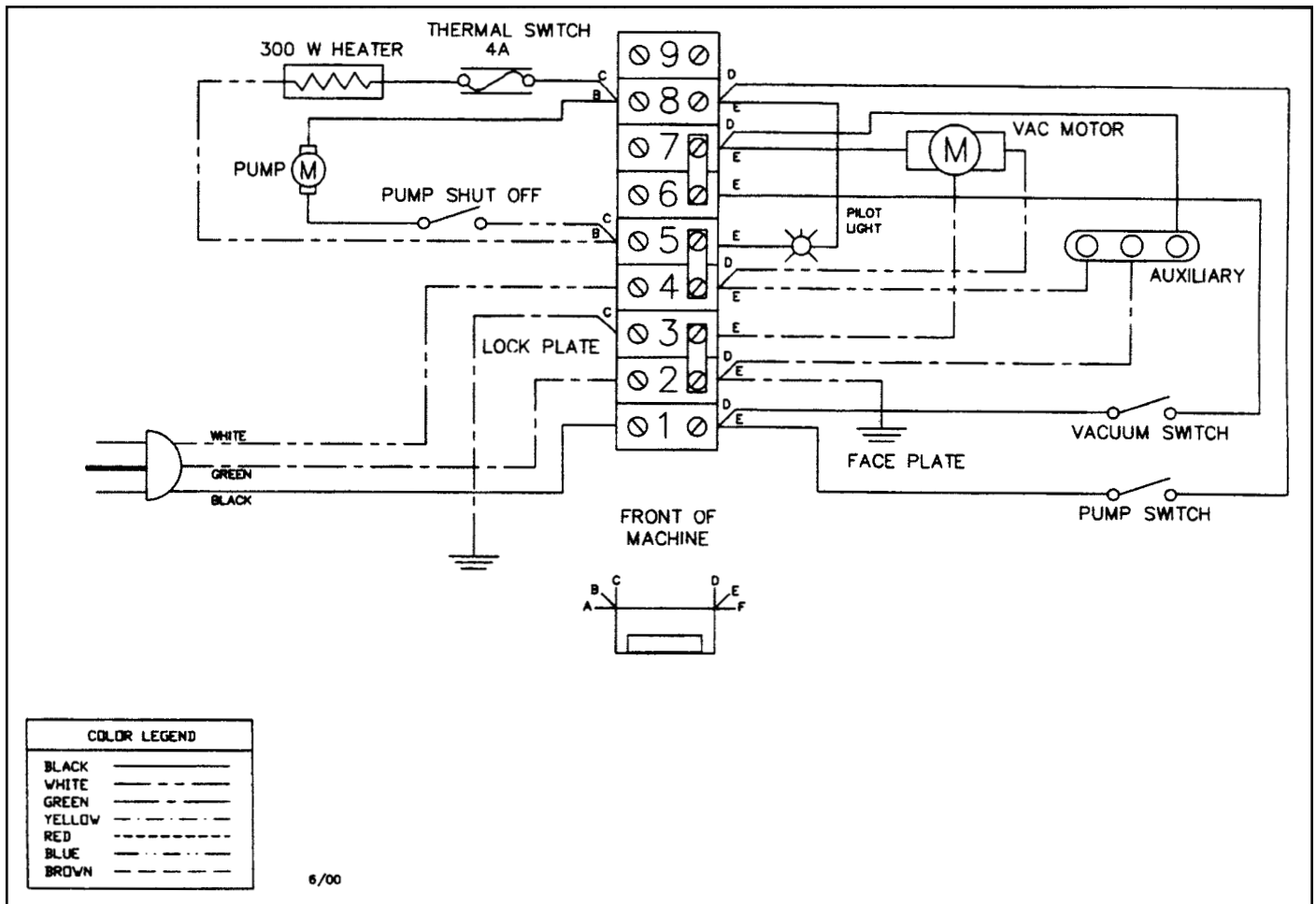

TROUBLESHOOTING

CONDITION	CAUSE	CORRECTION
System Will Not Operate	<ol style="list-style-type: none"> 1) Plugged into dead outlet 2) Blown fuse or breaker 3) Defective power cord 4) Defective switch 5) Loose wiring 6) Improper connection 	<ol style="list-style-type: none"> 1) Plug into live grounded outlet 2) Replace fuse or breaker 3) Replace power cord 4) Replace switch 5) Properly connect wiring 6) Press tightly into outlet
Vacuum Motor Will Not Run	<ol style="list-style-type: none"> 1) Main power not activated 2) Loose wiring 3) Defective vacuum switch 4) Defective vacuum motor 	<ol style="list-style-type: none"> 1) Active main power switch 2) Tighten and connect wiring 3) Replace vacuum switch 4) Replace vacuum motor
Pump Will Not Run	<ol style="list-style-type: none"> 1) Main power not activated 2) Defective pump switch 3) Loose wiring 4) Plugged spray jet 5) Lint buildup in hose coupling 6) Kink in solution hose 7) Defective pump 	<ol style="list-style-type: none"> 1) Activate main power 2) Replace pump switch 3) Tighten and connect wiring 4) Remove blockage 5) Disassemble and remove lint 6) Straighten hose 7) Replace pump
Pump Runs But Will Not Spray/Weak Spray	<ol style="list-style-type: none"> 1) Solution tank empty 2) Obstructed spray jet 3) Obstructed hose coupling 4) Obstructed solution filter 5) Hose damage 6) Pump components wearing out 	<ol style="list-style-type: none"> 1) Refill solution tank 2) Remove blockage 3) Remove obstruction 4) Clean filter 5) Replace necessary hose 6) Replace pump
Loss of Vacuum Suction	<ol style="list-style-type: none"> 1) Recovery dome not seated 2) Obstruction in vac hose 3) Obstruction in wand 4) Screen filter clogged 5) Recovery dome needs gasket 	<ol style="list-style-type: none"> 1) Re-seat for better seal 2) Remove obstruction 3) Remove obstruction 4) Remove debris 5) Replace dome gasket

THERMAX CP3 SCHEMATIC

REV. C

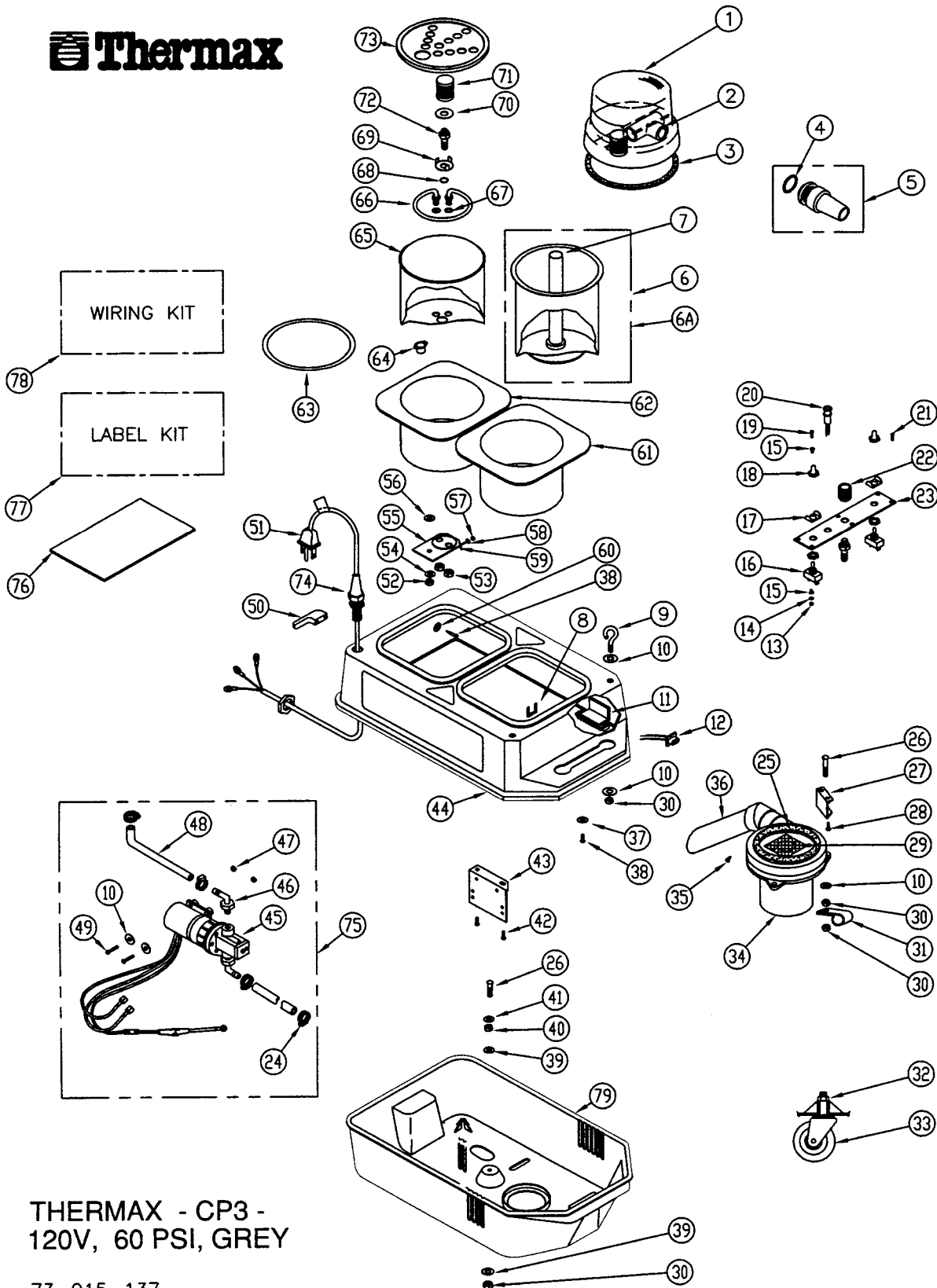

THERMAX - CP3 -
120V, 60 PSI, GREY

73-015-137

9/25/02
E73-015-136C.DWG

THERMAX CP3 PARTS LIST

ITEM NO.	THERMAX NO.	DESCRIPTION	ITEM NO.	THERMAX NO.	DESCRIPTION
1	24-003-108	ASSY, DOME, SMOKE, CP3	40	04-304-00	NUT, 1/4-20, HEX CAD
2	01-359-00	FITTING, PVC, "T", 1", CP3	41	04-256-00	WASHER, .25", INT LOCK
3	23-005-005	GASKET, DOME, CP3/CP12	42	04-019-00	SCREW, 8-32 X .375", HEX, SLOT, W/LOCK
4	05-255-00	O-RING, 1.046 ID, INLET, CP3/CP5	43	03-021-01	BRACKET, PUMP SUPPORT, CP3
5	23-035-002	ASSY, INLET, 1.25, SLP, CP3/CP5	44	34-026-001	ASSY, CASE UPPER, GRAY, W/O INSERTS
6	22-003-001	ASSY, RECOVERY TANK, ST.ST'L, CP3	45	31-060-120	ASSY, PUMP, CP3 120 FLOJET
6A	22-010-000	ASSY, RECOVERY TANK, PLASTIC, CP3	46	04-549-01	FITTING, .375 BARB, .375" MPT
7	22-116-01	ASSY, RISER TUBE, CP3/5	47	04-321-01	NUT, #10-32, NYLON SS
8	04-456-01	RETAINER, AUX OUTLET, SPRING STEEL	48	05-018-00	HOSE .375", PVC, - PRICE/FOOT
9	04-146-00	EYE BOLT, 1/4-20 X "1	49	04-056-01	SCREW, #10-32 X 1.0. PH, PHILL, SS
10	04-216-00	WASHER, FLAT, 25 X .75, SS	50	01-069-00	CLIP, CORD, BLACK, CP3/CP5
11	33-775-001	ASSY, TERMINAL BLOCK, 120V, CP3	51	27-001-111	ASSY, POWER CORD, 14-3, RING TERM
12	02-785-00	RECEPTICLE, AUX, CP3/CP5	52	04-306-00	NUT, 9/16 - 18, HEX JAM
13	04-301-00	NUT, 6-32, HEX CAD	53	04-308-00	NUT, 1/2-20 HEX
14	04-252-00	WASHER, #6, INT LOCK	54	04-276-00	WASHER, WAVE SPRING, .760 OD
15	02-751-00	EYELET, INSERT, CP3/CP5	55	03-005-00	PLATE, LOCK, CP3
16	02-514-00	SWITCH, TOGGLE, CP3/CP5	56	04-218-00	WASHER, FLAT, .625 X 1.125, ZINC
17	03-077	GUARD, SWITCH, CP3/CP5"	57	04-302-00	NUT, 8-32, HEX CAD
18	02-760-01	COVER, SWITCH, BLK, CP3, #1100	58	04-253-00	WASHER, #8, INT LOCK
19	04-037-00	SCREW, 6-32 X 1". PH PHIL, 18/8 SS	59	04-005-00	SCREW, 8-32 X .375 ZINC
20	32-578-121	KIT, PILOT LIGHT, 120V, 16" CP3/CP5	60	04-231-01	WASHER, FLAT, #10 X .75, ZINC
21	04-054-00	SCREW, #8 X .5", PH, PHIL, HILO, ZINC	61	34-212-108	ASSY, INERT, FRONT, DARK GRAY, CP3
22	03-455-02	DISCONNECT .375" BARB	62	34-207-100	ASSY, INSERT, REAR DARK, GRAY CP3
23	06-510-01	PLATE, FACE 2SW, 120 V, BLUE, CP3-2	63	05-262-00	O-RING, 4.987 ID, TANK SEAL, CP3
24	04-371-00	CLAMP, WORM, .312"	64	02-676-00	SWITCH, THERMAL, 4A, 1"
25	05-210-01	GASKET, .125 THK X 6.75 OD, VAC MTR	65	03-204-04	TANK, SOLUTION, W/O BP, 12-Y, CP3
26	04-144-00	BOLT, 1/4-20 X 1.25" CARR HD, SS	66	25-003-001F	ASSY, HEATER, 120V, CP3
27	03-065-00	BRACKET, VAC MOTOR, CP3	67	05-263-00	ORING, .484 ID, HEATER SEAL, CP3
28	04-057*00	SCREW, #10 X .5", PH, PHIL, HILO, ZINC	68	05-264-00	O-RING, .546 ID, OUT & HEATER SEAL
29	03-601-01	WHEEL REAR CP12	69	03-043-01	RETAINER, LINT FILTER, CP3/CP5/CP12
30	04-322-00	NUT, 1/4 -20, NYLOCK	70	05-216-01	GASKET, 2" OD X .125", W/ADH, LINT FLTR
31	04-362-00	CLAMP, .75", NYLON	71	37-706-000	ASSY, SOL FILTER, COM'L
32	04-324-00	NUT, 3/8-16, LOCK	72	03-464-01	FITTING, SOLUTION TANK, INLET
33	03-472-00	DISCONNECT, FEMALE, 1/4 NPT, CP12	73	24-003-004	ASSY, LID, SOLUTION TANK, GRAY, CP3
34	30-488-052-3	ASSY, VAC MOTOR, 120V, QK CONNECT	74	27-274-002	ASSY, STRAIN RELIEF
35	04-121-01	SCREW, 8-32 X .375", HX, SLOT, EXT SEM	75	32-711-120	KIT, RETROFIT, 60 PSI, 120V FLOJET
36	26-035-000-1	ASSY, EXHAUST, CP3	76	06-312-02	OWNERS MANUAL, CP3
37	04-242-00	WASHER, FLAT, #10 X 1.5, ZINC	77	32-402-000	LABEL KIT, CP3
38	04-055-00	SCREW, #10 X .75", PH, PHIL, HILO, ZINC	78	33-502-000	WIRING KIT, CP3
39	04-232-00	WASHER, FLAT, .25 X 1, SS	79	36-003-108-2	ASSY, LOWER CASE, GRAY, CP3/CP5

See your local distributor
for any other items, solutions, and spare parts or visit thermaxaf.com.

FLOOR WAND SCHEMATIC

REV. B

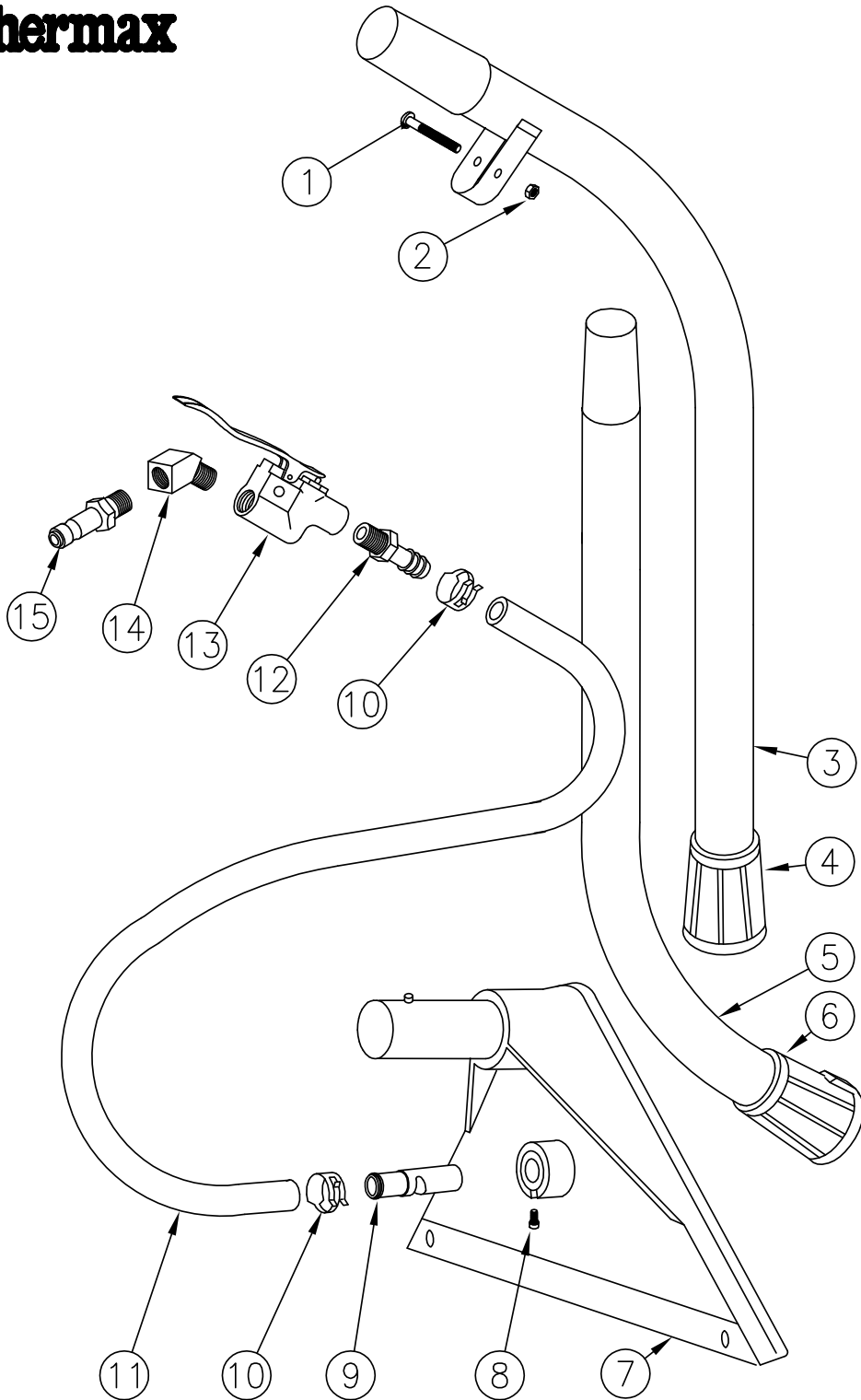

FLOOR WAND

29-760-325-1

FLOOR WAND PARTS LIST

ITEM NO.	THERMAX NO.	DESCRIPTION
1	04-028-01	SCREW, 10-32 X 1", PH, PHIL, ZINC
2	04-321-00	NUT, 10-32, NYLOCK
3	28-181-000	ASSY. UPPER WAND W/CUFF
4	01-315-00	CUFF, W/O RELEASE, GRAY, PB309
5	28-182-000	ASSY, LOWER WAND W/CUFF
6	01-316-00	CUFF, W/RELEASE, GRAY, PB309
7	28-203-125	ASSY, WET HD W/WEAR PLATE
8	04-001-02	SCREW, 4-40 X 1/4
9	03-450-01	NOZZLE, K2.5
10	04-352-01	CLAMP, .5", YELLOW
11	05-016-00	HOSE, .312" ID, VINYL BRAIDED - PRICE/FOOT
12	04-552-00	FITTING, .375 BARB .25 NPT, NYLON
13	29-561-000	ASSY, VALVE, WANDS, PLASTIC, CP3
14	03-459-00	FITTING, .25, 45 DEG, ELBOW
15	03-457-01	DISCONNECT, .25" MPT, CP3/PB309

See your local distributor
for any other items, solutions, and spare parts or visit thermaxaf.com.

UPHOLSTERY WAND SCHEMATIC

REV. A

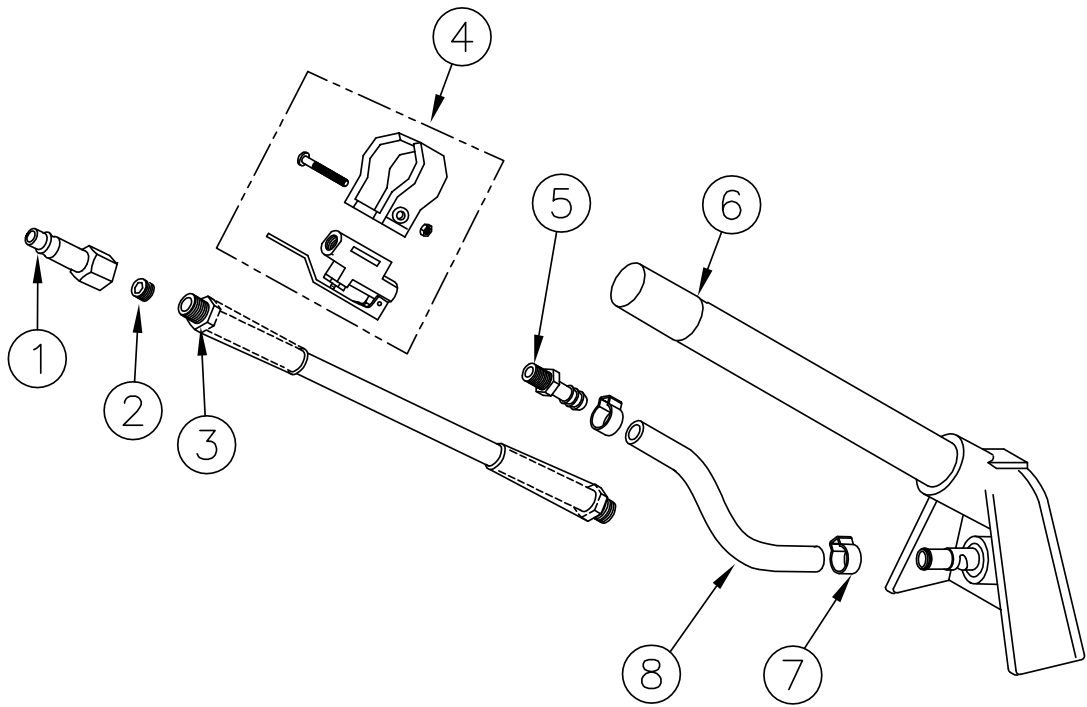

HAND WAND 1.25" SLIM LINE

35-255-004

5/11/04

E35-255-004.DWG

UPHOLSTERY WAND PARTS LIST

ITEM NO.	THERMAX NO.	DESCRIPTION
1	04-457-06	MALE DISCONNECT 1/4 FTP
2	04-002-00	SCREW, 3/8 - 24 X 3/8 SOCKET SET
3	04-161-00	HOSE ASSEMBLY
4	29-561-0001	ASSY, VALVE, BRASS, W/HANDLE HW
5	03-466-01	HOSE BARB 3/16 X 1/8 MPT
6	35-273-000	ASSY, STEAM HEAD, 4" X 1.25" W/PLATE
7	04-359-00	CLAMP, HOSE, .437, SINGLE EAR
8	05-019-00	HOSE, 3187, BRAIDED VINYL PRICE/FOOT

See your local distributor
for any other items, solutions, and spare parts or visit thermaxaf.com.

POWER BRUSH SCHEMATIC

REV. B

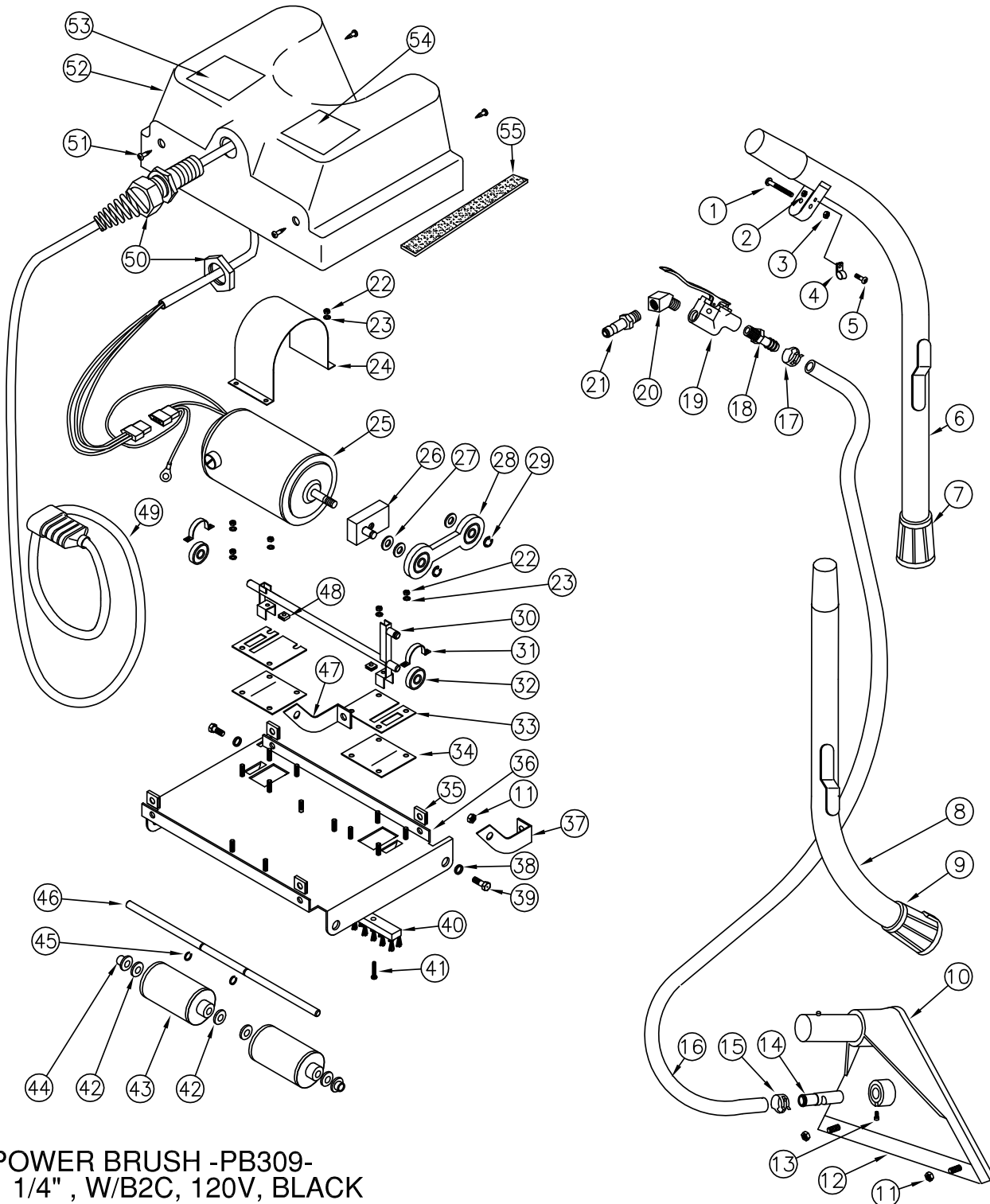

POWER BRUSH -PB309-
1 1/4" , W/B2C, 120V, BLACK

80-012-121

7/19/04
E80-012-121B.DWG

POWER BRUSH PARTS LIST

ITEM NO.	THERMAX NO.	DESCRIPTION			
1	04-028-01	SCREW, 10-32X1". PH, PHIL, ZINC	29	04-459-00	RETAINER, E-CLIP, LARGE
2	04-323-00	NUT, 8-32, NYLOCK	30	03-807-02	ASSY, SHAFT, BRUSH, PB309
3	04-321-01	NUT, #10-32, NYLON SS	31	03-069-02	RETAINER, BEARING, PB309
4	04-364-00	CLAMP, POWER CORD, PB309	32	03-078-00	BEARING, BRUSH SHAFT, PB309
5	04-005-00	SCREW, 8-32 X .375 ZINC	33	03-061-00	GUARD, SPLASH, PB309
6	28-307-015	ASSY, WAND UPPER, PB309	34	01-148-02	COVER, DUST, PB309N
7	01-315-00	CUFF, W/O RELEASE, GRAY, PB309	35	04-334-00	CLIP, TINNEMAN, U TYPE
8	28-308-00	ASSY, LOWER WAND, PB309	36	03-071-04	PLATE, BASE, PB309
9	01-316-00	CUFF, W/RELEASE, GRAY, PB309	37	03-072-00-2	BRACKET, HINGE, RH
10	28-203-900	ASSY, PB309 STM H'D, W/WEAR PLATE	38	04-243-00	WASHER, SS
11	04-322-00	NUT, 1/4 -20, NYLOCK	39	04-143-00	BOLT, 1/4-20 X .5", HEX HD, SS
12	03-060	PLATE, WEAR, STMHD, PB309	40	05-344-01	BRUSH, 8.375", PB309
13	04-001-02	SCREW, 4-40 X 1/4	41	04-041-01	SCREW, 8-32 X .625", RH, PHIL, SS
14	03-450-01	NOZZLE, K2.5	42	04-245	WASHER, FLAT, .225 X .566, SS
15	04-352-01	CLAMP, .5", YELLOW	43	20-355-003	ASSY, SINGLE ROLLER HUB
16	05-016-00	HOSE, .312" ID, VINYL BRAIDED - PRICE/FOOT	44	05-353-00	BUSHING, FLANGE, NYLON, WHT, PB309
17	04-353-00	CLAMP, HOSE, .437, RED	45	04-459-01	RETAINER, C CLIP
18	04-552-00	FITTING, .375 BARB .25 NPT, NYLON	46	03-815-09	SHAFT, AXLE, PB309
19	29-561-000	ASSY, VALVE, WANDS, PLASTIC, CP3	47	03-072-01-2	BRACKET, HINGE, LH
20	03-459-00	FITTING, .25, 45 DEG, ELBOW	48	04-330-00	CLIP, TINNEMAN, J TYPE
21	03-457-01	DISCONNECT, .25" MPT, CP3/PB309	49	27-420-111	ASSY, POWER CORD, 15', PB309
22	04-303-00	NUT, 10-32, HEX BRASS	50	27-274-002	ASSY, STRAIN RELIEF
23	04-273-20	WASHER, #10 LOCK	51	04-090-00	SCREW, #8 X.5", PH, PHIL, "A" SS
24	04-380-03	STRAP, MOTOR, PB309	52	34-151-100	ASSY, HOUSING, BLACK, PB309
25	30-055-120	ASSY, MOTOR, PB309	53	06-245-04	LABEL, WARNING, PB309
26	37-001-001	ASSY, COUNTER WEIGHT, PB309	54	06-245-05	LABEL, SPRAY STROKE, PB309
27	40-0770012	SPACER, STEEL, #5702-258-60	55	05-201-02	GASKET, .5 X .062, NEO, W/ADH PRICE/FOOT
28	03-067-01	DRIVE LINK, W/BEARING			

See your local distributor
for any other items, solutions, and spare parts or visit thermaxaf.com.

ADDITIONAL COMMERCIAL UNITS

Also available to make your job easier, the Thermax CP5 or the DV12 gives you the power and efficiency to clean carpets and upholstery in both commercial and residential settings.



THERMAX CP5

The Thermax CP5 is an industry proven performer, built to endure the most demanding carpet and upholstery extraction cleaning applications. Constructed in a portable footprint easily operated by one individual, the CP5 is designed to attain the highest level of professional cleaning results!

- Powerful two-stage vacuum motor for increased recovery speed and quicker drying time (112" water lift).
- Built-in 1800-watt dual solution heating system for uniform temperature control (up to 175°).
- 5-Gallon hygienic stainless steel solution and recovery tanks.
- High-impact, chemical resistant housing with conditional lifetime warranty - virtually indestructible.
- 100 psi high-efficiency demand solution pump.
- Multi-option wand and hose packages for vacuum and extraction versatility are available.



Thermax Steam Cleaning Solutions are also available for purchase in commercial sizes of one-, five-, or fifty-five-gallon



THERMAX DV12

The DV12 is Thermax's newest industrial steam cleaner, which aggressively removes dirt, grime, odors and other embedded pollutants with unmatched efficiency.

- Powerful dual two-stage vacuum motors (165" water lift) for faster cleaning, increased recovery speed and quicker drying time.
- Built-in 1800-watt solution pre-heating system for quick, uniform temperature control (up to 175°).
- 11-Gallon hygienic stainless steel solution tank.
- 12-Gallon large capacity recovery tank with automatic overflow protection shut-off and waste gate empty system.
- Single 25' power cord for one circuit operation.
- High-impact, chemical resistant housing with conditional lifetime warranty - virtually indestructible.
- 100 psi high-efficiency demand solution pump.
- Engineered for mobility and stability, tip resistant operation.
- Built-in dolly handle for greater control and maneuverability.
- Large 8" rear wheels make it easy to go up and down stairs.
- Marine sealed switches.

CP3 WARRANTY

The Thermax CP3 is warranted to be free from Manufacturer's defect for a period of one (1) year on all non-electrical and electrical components.

1) Warranty extended only to original owner. Proof of purchase required.

Brass quick-disconnects, "O" rings, diaphragms, seals, grommets, gaskets, or any rubber or synthetic rubber or rubber-like parts are considered expendable in normal use and service, therefore are not included in this warranty.

The Manufacturer's obligation under this warranty is limited to repairing or replacing with Manufacturer's specified replacement parts, free of charge and without charge for installation, and parts that prove, in the judgement of the Manufacturer or its authorized service center, to be defective in material or workmanship.

WARNING ON CLEANING SOLUTIONS: Use of other than Thermax cleaning solutions will void warranty. Must use defoamer in recovery tank of CP3.

This warranty shall not apply: (1) to normal maintenance services or adjustments, including, but not limited to, cleaning of the system as recommended by the Manufacturer; nor (2) to systems which shall have been altered or used in any way which, in the opinion of the Manufacturer or its service center, adversely affects the performance; nor (3) shall this warranty apply if the serial number is missing, altered, or defaced, or in the case of a defect or damages resulting from inadequate voltage, blown fuses, damage due to freezing, accidental damage to finish or components, abuse, misuse or act of God.

We request that the original owner write or call for authorization to return any items under warranty. Defective parts under warranty must be returned to Manufacturer for inspection unless otherwise authorized by Manufacturer. Upon inspection and Manufacturer determination, proper action regarding warranty will be taken, including an appropriate refund, credit on parts, labor or shipping. This warranty also excludes any rental equipment expenses incurred or loss of business claims of any nature due to break down of the system.

There are no warranties which extend beyond the description on the face hereof, and this warranty is in lieu of any other warranty, expressed or implied, and expressly limits the term of this warranty, any implied warranty of merchantability or fitness for a particular purpose. This warranty constitutes the sole and exclusive remedy for any defect in or non-performance of or use of the Thermax CP3 cleaning system and under no circumstances shall the Manufacturer be liable for any claimed or consequential damages arising there from.

NOTICE: Failure to complete and return the attached warranty card or to register warranty online at thermaxaf.com within thirty (30) days from date of purchase shall render this warranty null and void. Warranty card must be returned to Manufacturer! Staple your copy of the warranty card to this manual.

Name of Distributor

Distributor Phone Number

Date of Purchase

Serial Number

PLEASE NOTE: Retain this owner's manual along with your copy of the Warranty Registration Form. Proof of purchase must accompany all warranty claims.



World Headquarters

3315 East Texas St.

Bossier City, LA 71111

1-888-764-3700

Website: thermaxaf.com

Email: customersupport@thermaxaf.com

info@thermaxaf.com